



# GENERAL WARNINGS AND CAUTIONARY STATEMENTS FOR REMOVABLE BOLLARDS

In order to safely and effectively use any TrafficGuard<sup>®</sup>, Inc. product, please read and understand the General Warnings and Cautionary Statements contained below. If you have any questions about any of these General Warnings and Cautionary Statements, or about any aspect of TrafficGuard<sup>®</sup>, Inc.'s products or literature, please contact TrafficGuard<sup>®</sup>, Inc. at 877-727-7347, or email [sales@trafficguard.net](mailto:sales@trafficguard.net).



## **BOLLARD SELECTION AND PLACEMENT**

based on vehicle weight, speed and other site specific factors to be determined by owner.



## **FAILURE TO UTILIZE TRAFFICGUARD<sup>®</sup>, INC. AUTHORIZED PARTS, OR MODIFICATIONS**

to the TrafficGuard<sup>®</sup>, Inc. products, or failure to follow the recommended installation procedures, will result in your warranty being null and void.



## **READ AND FULLY UNDERSTAND THE INSTALLATION INSTRUCTIONS**

before attempting to install any TrafficGuard<sup>®</sup>, Inc. bollard product.



## **SUBSTITUTION OF COMPONENTS MAY IMPAIR THE PROPER FUNCTION**

of TrafficGuard<sup>®</sup>, Inc. bollards products. If you need replacement parts, please contact TrafficGuard<sup>®</sup>, Inc. at the number and email above.



**WARNING: FAILURE TO FILL/COVER AN OPEN GROUND SLEEVE ON ALL REMOVABLE BOLLARDS MAY RESULT IS DAMAGE TO VEHICLES OR INJURY TO PEDESTRIANS. ALWAYS FILL/COVER THE GROUND SLEEVE PER TRAFFICGUARD<sup>®</sup>, INC. INSTRUCTIONS.**



## **REPLACEMENT GROUND SLEEVE FILLER PIECES ARE AVAILABLE**

for purchase at TrafficGuard<sup>®</sup>, Inc. For purchase of replacement ground sleeve filler pieces or other components, please contact TrafficGuard<sup>®</sup>, Inc. at the number or email above.



**CAUTION: BOLLARD MUST ALWAYS BE SECURED WITH LOCK MECHANISM WHEN BOLLARD IS IN THE GROUND SLEEVE TO AVOID MISUSE.**



## **FOR MAXIMUM EFFECTIVENESS**

of TrafficGuard<sup>®</sup>, Inc. bollard products, be sure to properly maintain bollards by replacing any damaged, corroded or missing components, and reapply paint as required to maximize visibility. Failure to properly maintain product can negatively impact the bollards performance over time.



## **TO ENSURE VISIBILITY**

of bollards, be sure to apply all decals that are provided with the product, and in the manner recommended by TrafficGuard<sup>®</sup>, Inc.

**IF IN DOUBT CALL TRAFFICGUARD<sup>®</sup>, INC. 877-727-7347**



# INSTALLATION DETAILS

## FOR RP3500 SERIES KEY LOCK REMOVABLE BOLLARDS

- 1 NEVER ATTEMPT TO PLACE THE BOLLARD INTO THE GROUND SLEEVE WHILE IN THE LOCKED POSITION.**
- 2 PAY CAREFUL ATTENTION** to the placement of the location of the ground sleeve latch pin – this determines the location of the lock at the top of the post.
- 3 INSTALLATION OF A SMALLER FOUNDATION** than that specified may reduce the overall impact capacity of the TrafficGuard, Inc. Bollard System.
- 4 TO PROTECT AGAINST A TRIP HAZARD** insert the galvanized ground sleeve filler piece at all times the bollard is removed from the ground sleeve insert.
- 5 PROPER DRAINAGE IS CRITICAL** to the life of the bollard and the locking system. You must keep water from standing in the hole.

**IF YOU HAVE ANY CONCERNS OR QUESTIONS** before beginning the installation please call **TRAFFICGUARD, Inc. 877-727-7347 TOLL FREE.**

4

3

2

1

**NOTE:**  
 - ALL DIMENSION GIVEN IN INCHES.  
 - GRIND AND SMOOTH ALL EDGES, BURRS, AND CORNERS

TOLERANCE -  
 0.X - +/- 0.1 INCHES  
 0.XX - +/- 0.06 INCHES  
 0.XXX - +/- 0.02 INCHES  
 ANGULAR - +/- 1'  
 FRACTION - +/- 1/16

REVISIONS				
ZONE	REV	DESCRIPTION	DATE	APPROVED

USE #3 SCHEDULE 40 STEEL END CAP HEMISPHERICAL DOME  
 NOTE: PREP BOTH THE TUBE AND CAP FOR WELDING - GRIND AND SMOOTH CONTACT SURFACE AFTER WELD.



USE #4 SCHEDULE 40 STEEL END CAP HEMISPHERICAL DOME  
 NOTE: PREP BOTH THE TUBE AND CAP FOR WELDING - GRIND AND SMOOTH CONTACT SURFACE AFTER WELD.



USE #6 SCHEDULE 40 STEEL END CAP HEMISPHERICAL DOME  
 NOTE: PREP BOTH THE TUBE AND CAP FOR WELDING - GRIND AND SMOOTH CONTACT SURFACE AFTER WELD.



NOTE - BAYONETTE MOUNT ON ONE SIDE ONLY (ALL SIZES)

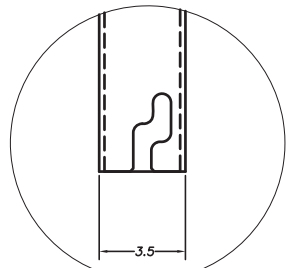

VIEW A  
3:1

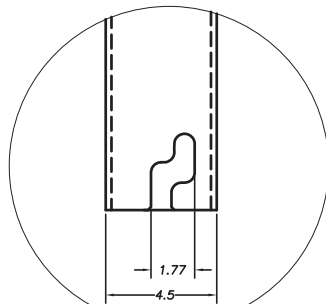

VIEW B  
3:1

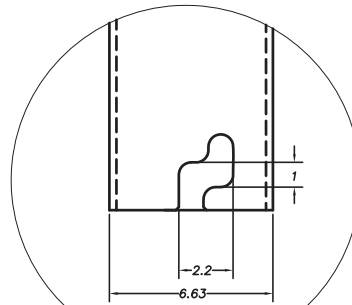

VIEW C  
3:1

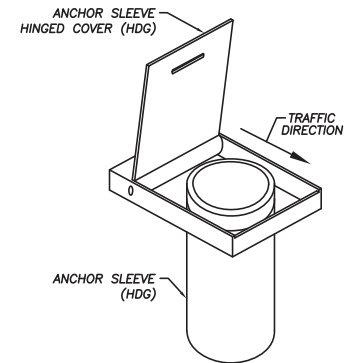
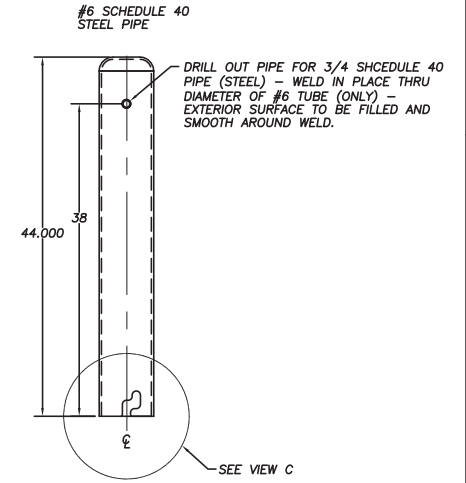
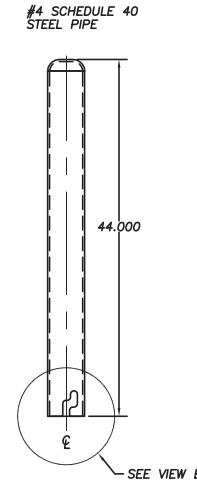
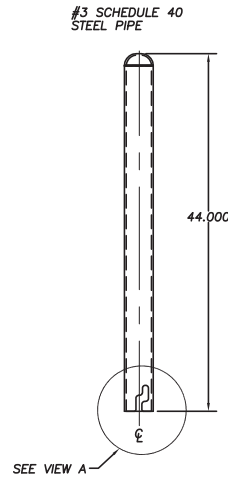

**ALTERNATE ANCHOR SLEEVE, LIDDED GROUND SLEEVE**

**GENERAL SPECIFICATIONS AND NOTES FOR ALL PARTS AND WELDMENTS**

- 1). ALL STEEL WORK SHALL CONFORM TO THE AISC "SPECIFICATION FOR THE DESIGN, FABRICATION, AND ERECTION OF STRUCTURAL STEEL BUILDINGS" - LATEST EDITION UNLESS NOTED ON THE DRAWING.
- 2). ALL WELDING SHALL BE PERFORMED BY QUALIFIED WELDERS AND SHALL CONFORM TO THE AMERICAN WELDING SOCIETY ANSI/AWS D1.1 - LATEST EDITION OF THE STRUCTURAL WELDING CODE - STEEL
- 3). ALL MATERIAL SHALL BE NEW AND SHAL BE AS NOTED ON THE DRAWING AND/OR IN THE BILL OF MATERIAL. SS INDICATES STAINLESS STEEL AND HDG INDICATES HOT DIPPED GALVANIZED STEEL.
- 4). ALL PAINTING WORK SHALL CONFORM TO THE MANUFACTURERS SPECIFICATION AND INSTALLATION INSTRUCTIONS AND THE SSPC (STEEL STRUCTURES PAINTING COUNCIL) AND AS NOTED ON THE DRAWING.
- 5). ALL HOLE CENTER DIMENSIONS SHALL HAVE A +/- 1/16 INCH TOLLERANCE AND ALL OTHER DIMENSIONS SHALL HAVE A +/- 1/8 INCH TOLLERANCE UNLESS NOTED ON THE DRAWING.
- 6). ALL WORK SHALL BE PACKAGED AND SHIPPED PER SPECIFIC INSTRUCTIONS BY PARS DIRECT.

THIS DRAWING MAY NOT BE USED OR REPRODUCED EXCEPT WHEN AUTHORIZED IN WRITING BY TRAFFIC GUARD.

TrafficGuard, Inc.  
 P.O. Box 351 Geneva, Illinois 60134  
 Toll Free (877) 727-7247  
 Fax (630) 365-1947

REVISION	SCALE	RELEASE DATE	HEIGHT	SHEET	DWG NO	RPT - All post sizes	REV

4

3

2

1

# CONSTRUCTION DATA SCHEDULE RPAS

1. THE DESIGN LOAD IS A STATIC LOAD "P" APPLIED AT 27 INCHES ABOVE GRADE.
2. THE EARTH PRESSURE VALUE IS SHOWN AT DESIGN LOAD AND THE OWNER SHOULD VERIFY THAT THE EARTH IS ADEQUATE TO WITHSTAND THE NOTED EARTH DESIGN PRESSURE.
3. ANCHORAGE SYSTEMS BY OTHERS THAN TRAFFICGUARD,<sup>®</sup> INC. MAY CAUSE PREMATURE FAILURE OF THE BOLLARD.

NOTE: CONCRETE, FORM, ROCK, PVC DRAIN AND REBAR PROVIDED BY OTHERS										
DESIGN LOAD P	BOLLARD		EARTH "Q" MAX.	PIER HT. "C" MIN.	VERT. REBAR		HOOP TIES	PIER CONCRETE	FRENCH DRAIN	PIER "D"
	Out Dia.	Ins Dia.			LENGTH	QTY				
600 #	1.910"	1.620"	992 PSF	42 INCH	38 INCH	3	6 EA.	6 Cu Ft	1.2 CF	8"
1200 #	2.440"	2.064"	1984 PSF	42 INCH	38 INCH	3	6 EA.	6 Cu Ft	1.2 CF	8"
3000 #	3.500"	3.068"	2204 PSF	42 INCH	38 INCH	4	6 EA.	6 Cu Ft	0.5 CF	18"
6000 #	4.500"	4.026"	4408 PSF	42 INCH	38 INCH	4	6 EA.	6 Cu Ft	0.5 CF	18"
6000 #	4.500"	4.026"	2667 PSF	54 INCH	50 INCH	4	7 EA.	8 Cu Ft	0.5 CF	18"
10000#	5.563"	5.047"	4444 PSF	54 INCH	50 INCH	4	7 EA.	8 Cu Ft	0.5 CF	18"
10000#	5.563"	5.047"	3600 PSF	60 INCH	56 INCH	4	8 EA.	9 Cu Ft	0.5 CF	18"
10000#	5.563"	5.047"	2975 PSF	66 INCH	62 INCH	4	8 EA.	10 Cu Ft	0.5 CF	18"
15000#	6.625"	6.065"	3750 PSF	72 INCH	68 INCH	4	9 EA.	11 Cu Ft	0.5 CF	18"
15000#	6.625"	6.065"	3195 PSF	78 INCH	72 INCH	4	9 EA.	12 Cu Ft	0.5 CF	18"
15000#	6.625"	6.065"	3240 PSF	60 INCH	56 INCH	8	8 EA.	25 Cu Ft	1.6 CF	30"
15000#	6.625"	6.065"	3333 PSF	54 INCH	50 INCH	8	7 EA.	32 Cu Ft	1.8 CF	36"

THIS IS A GUIDELINE FOR ESTIMATING, SITE SPECIFIC CONDITIONS SHOULD BE VERIFIED.  
 This Drawing shall not be used nor reproduced except when authorized in writing by TrafficGuard,<sup>®</sup> Inc.

## ROUND POST BOLLARD RPAS ANCHORAGE SYSTEM DETAILS

THIRD ANGLE PROJECTION   
 Do not scale from drawing

Toll Free **TrafficGuard,<sup>®</sup> Inc.**  
 P.O. Box 201, Geneva, IL. 60134  
 Bus: 1.877.727.7347 Fax: 1.800.814.7194

Rev.	Date	by	Description	Action	by	Dwg. Scale:	nts	Assembly Shipping Weight	Drawing Number:
3	-	-	-	Design	wkz	Dwg. Scale:	nts	Varies per Model	RPAS-2
2	-	-	-	Drawn	wkz	Copywrite:	2010	Varies per Model	RPAS-2
1	-	-	-	Checked	wkz	Dwg. Size:	Letter	Drawing Date:	12.10.10
									Sheet: 2 of 2

# PIER ELEVATION SECTION

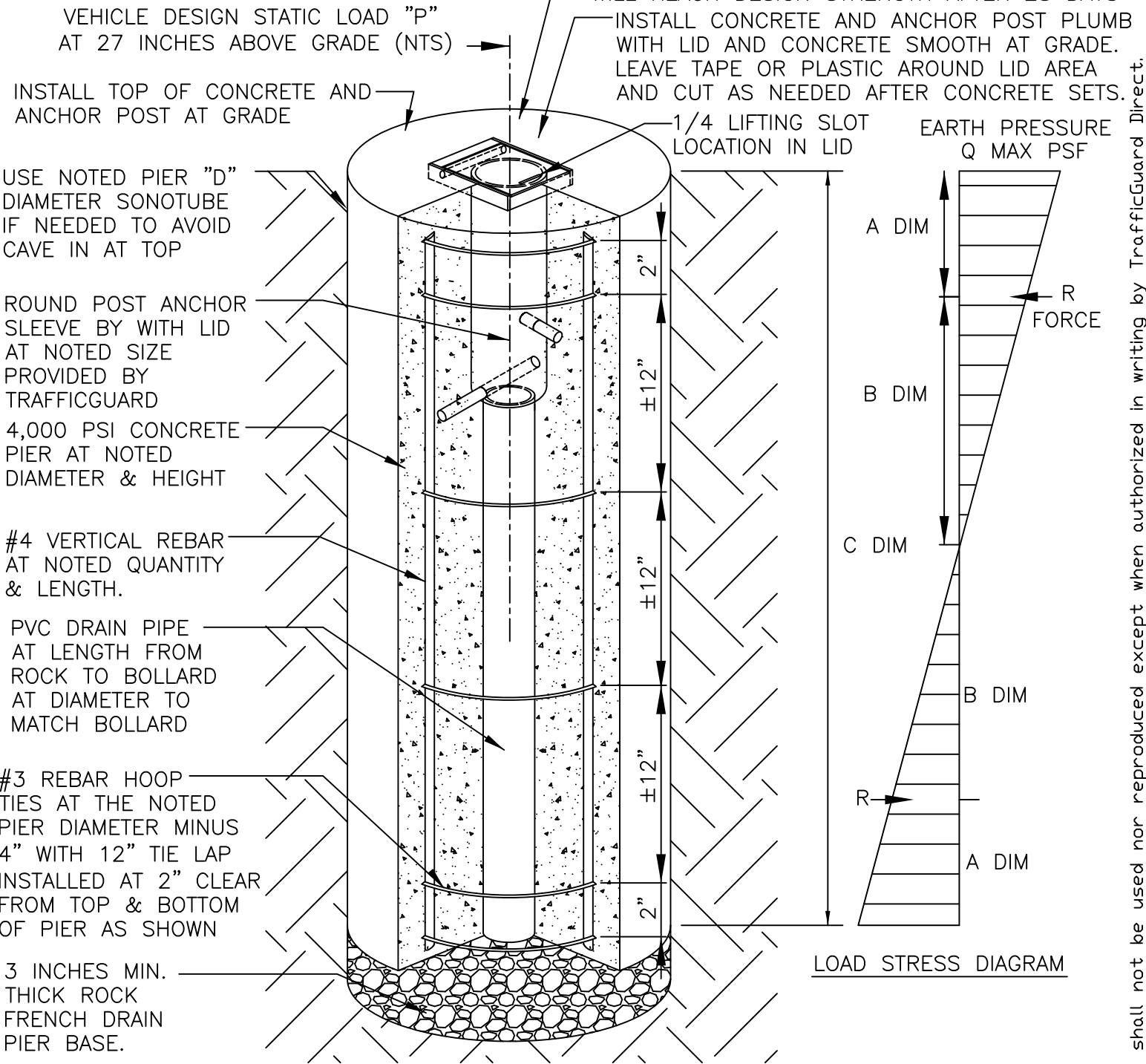

This Drawing shall not be used nor reproduced except when authorized in writing by TrafficGuard Direct.

HOOP REBAR #3	PROVIDED BY OWNER		
VERTICAL REBAR #4	PROVIDED BY OWNER	CONCRETE AND ROCK	PROVIDED BY OWNER
SONOTUBE FORM TUBE	PROVIDED BY OWNER	DRAIN PVC PIPE	PROVIDED BY OWNER
DESCRIPTION	REMARKS	DESCRIPTION	REMARKS

**NOTE** REFER TO RPAS-2 FOR THE ANCHORAGE SYSTEM DIMENSIONS, DESIGN LOADS, REBAR SIZE, QUANTITIES, AND OTHER DESIGN DATA.

LID ROUND POST BOLLARD LRPAS ANCHORAGE SYSTEM ASSEMBLY		THIRD ANGLE PROJECTION	Toll Free		TrafficGuard®	
Do not scale from drawing			P.O. Box 201, Geneva, IL. 60134		Bus: 1.877.727.7347 Fax: 1.800.814.7194	
3	-	-	-	Action	by	
2	-	-	-	Design	wkz	Dwg. Scale: nts
1	-	-	-	Drawn	wkz	Copywrite: 2010
Rev.	Date	by	Description	Checked	wkz	Dwg. Size: Letter
				Drawing Date: 12.10.10		Drawing Number: LRPAS1
				Sheet: 1 of 2		