



GENERAL WARNINGS AND CAUTIONARY STATEMENTS FOR REMOVABLE BOLLARDS

In order to safely and effectively use any TrafficGuard[®], Inc. product, please read and understand the General Warnings and Cautionary Statements contained below. If you have any questions about any of these General Warnings and Cautionary Statements, or about any aspect of TrafficGuard[®], Inc.'s products or literature, please contact TrafficGuard[®], Inc. at 877-727-7347, or email sales@trafficguard.net.



BOLLARD SELECTION AND PLACEMENT

based on vehicle weight, speed and other site specific factors to be determined by owner.



FAILURE TO UTILIZE TRAFFICGUARD[®], INC. AUTHORIZED PARTS, OR MODIFICATIONS

to the TrafficGuard[®], Inc. products, or failure to follow the recommended installation procedures, will result in your warranty being null and void.



READ AND FULLY UNDERSTAND THE INSTALLATION INSTRUCTIONS

before attempting to install any TrafficGuard[®], Inc. bollard product.



SUBSTITUTION OF COMPONENTS MAY IMPAIR THE PROPER FUNCTION

of TrafficGuard[®], Inc. bollards products. If you need replacement parts, please contact TrafficGuard[®], Inc. at the number and email above.



WARNING: FAILURE TO FILL/COVER AN OPEN GROUND SLEEVE ON ALL REMOVABLE BOLLARDS MAY RESULT IN DAMAGE TO VEHICLES OR INJURY TO PEDESTRIANS. ALWAYS FILL/COVER THE GROUND SLEEVE PER TRAFFICGUARD[®], INC. INSTRUCTIONS.



REPLACEMENT GROUND SLEEVE FILLER PIECES ARE AVAILABLE

for purchase at TrafficGuard[®], Inc. For purchase of replacement ground sleeve filler pieces or other components, please contact TrafficGuard[®], Inc. at the number or email above.



CAUTION: BOLLARD MUST ALWAYS BE SECURED WITH LOCK MECHANISM WHEN BOLLARD IS IN THE GROUND SLEEVE TO AVOID MISUSE.



FOR MAXIMUM EFFECTIVENESS

of TrafficGuard[®], Inc. bollard products, be sure to properly maintain bollards by replacing any damaged, corroded or missing components, and reapply paint as required to maximize visibility. Failure to properly maintain product can negatively impact the bollards performance over time.



TO ENSURE VISIBILITY

of bollards, be sure to apply all decals that are provided with the product, and in the manner recommended by TrafficGuard[®], Inc.

IF IN DOUBT CALL TRAFFICGUARD[®], INC. 877-727-7347



INSTALLATION DETAILS

FOR RP3500 SERIES KEY LOCK REMOVABLE BOLLARDS

- 1 NEVER ATTEMPT TO PLACE THE BOLLARD INTO THE GROUND SLEEVE WHILE IN THE LOCKED POSITION.**
- 2 PAY CAREFUL ATTENTION** to the placement of the location of the ground sleeve latch pin – this determines the location of the lock at the top of the post.
- 3 INSTALLATION OF A SMALLER FOUNDATION** than that specified may reduce the overall impact capacity of the TrafficGuard, Inc. Bollard System.
- 4 TO PROTECT AGAINST A TRIP HAZARD** insert the galvanized ground sleeve filler piece at all times the bollard is removed from the ground sleeve insert.
- 5 PROPER DRAINAGE IS CRITICAL** to the life of the bollard and the locking system. You must keep water from standing in the hole.

IF YOU HAVE ANY CONCERNS OR QUESTIONS before beginning the installation please call **TRAFFICGUARD, Inc. 877-727-7347 TOLL FREE.**

ROUND POST HELIX LOCK BOLLARD SERIES

| REV | BY | DATE | DESCRIPTION |
|-----|----|------|-------------|
| - | - | - | - |
| - | - | - | - |
| - | - | - | - |

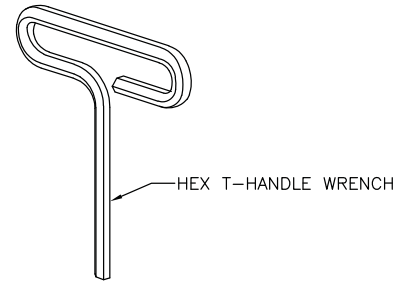
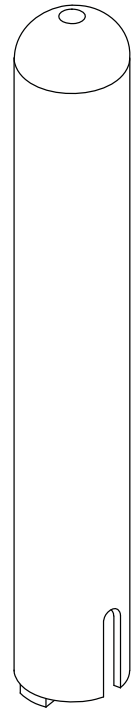
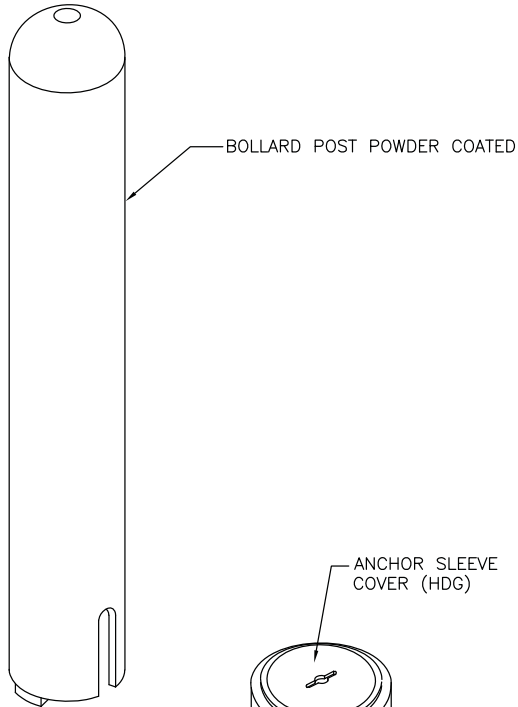

ATTACH REFLECTIVE WARNING LABELS PROVIDED TO THE FRONT & BACK OF BOLLARD AFTER INSTALLATION

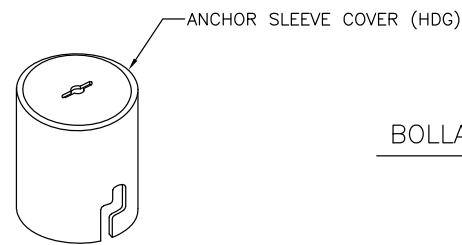
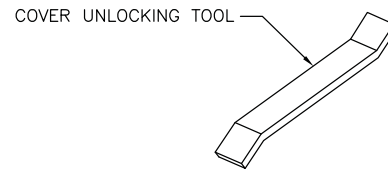
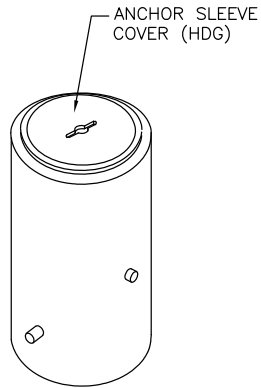
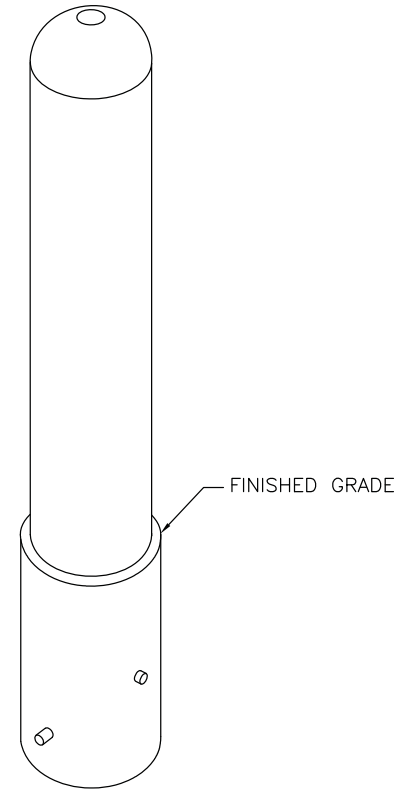

BOLLARD REMOVED POSITION

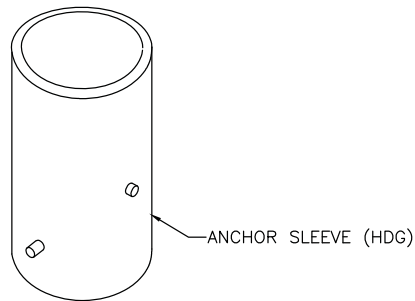

BOLLARD INSTALLED POSITION

| | | | |
|---|----|----|----|
| 7 | | | |
| 6 | | | |
| 5 | | | |
| 4 | | | |
| 3 | | | |
| 2 | | | |
| 1 | -- | -- | -- |

| ITEM | PART NUMBER | QTY. | DESCRIPTION | BILL OF MATERIAL |
|------|-------------|------|-------------|------------------|
|------|-------------|------|-------------|------------------|

This Drawing shall not be used nor reproduced except when authorized in writing by TrafficGuard,® Inc.

| | | | | |
|--|--|---|---|---|
| TrafficGuard,® Inc. www.trafficguard.net P.O. Box 201, Geneva, IL. 60134 Bus: 877-727-7347 Fax: 800-814-7194 | | NAME: HELIXLOCK BOLLARD INSTALL USED IN: -- 1. DO NOT SCALE FROM DRAWING 2. UNITS ARE IN INCHES UN. 3. DIMENSIONING BASED IN ASME Y14.5M-1994 | ACTION BY: -- DESIGN: -- DRAWING: DDE CHECKED: -- 0.X = ± 0.1 0.XX = ± 0.06 ANGULAR = ± 1° FRACTION = 1/16 | DRAWING NUMBER: -- SCALE: -- DATE: 01/16/12 SIZE: -- COPYRIGHT: -- SHT: 1 of 1 |
|--|--|---|---|---|

CONSTRUCTION DATA SCHEDULE RPAS

1. THE DESIGN LOAD IS A STATIC LOAD "P" APPLIED AT 27 INCHES ABOVE GRADE.
2. THE EARTH PRESSURE VALUE IS SHOWN AT DESIGN LOAD AND THE OWNER SHOULD VERIFY THAT THE EARTH IS ADEQUATE TO WITHSTAND THE NOTED EARTH DESIGN PRESSURE.
3. ANCHORAGE SYSTEMS BY OTHERS THAN TRAFFICGUARD,[®] INC. MAY CAUSE PREMATURE FAILURE OF THE BOLLARD.

| NOTE: CONCRETE, FORM, ROCK, PVC DRAIN AND REBAR PROVIDED BY OTHERS | | | | | | | | | | |
|--|----------|----------|----------------|-------------------|-------------|-----|-----------|---------------|--------------|----------|
| DESIGN LOAD P | BOLLARD | | EARTH "Q" MAX. | PIER HT. "C" MIN. | VERT. REBAR | | HOOP TIES | PIER CONCRETE | FRENCH DRAIN | PIER "D" |
| | Out Dia. | Ins Dia. | | | LENGTH | QTY | | | | |
| 600 # | 1.910" | 1.620" | 992 PSF | 42 INCH | 38 INCH | 3 | 6 EA. | 6 Cu Ft | 1.2 CF | 8" |
| 1200 # | 2.440" | 2.064" | 1984 PSF | 42 INCH | 38 INCH | 3 | 6 EA. | 6 Cu Ft | 1.2 CF | 8" |
| 3000 # | 3.500" | 3.068" | 2204 PSF | 42 INCH | 38 INCH | 4 | 6 EA. | 6 Cu Ft | 0.5 CF | 18" |
| 6000 # | 4.500" | 4.026" | 4408 PSF | 42 INCH | 38 INCH | 4 | 6 EA. | 6 Cu Ft | 0.5 CF | 18" |
| 6000 # | 4.500" | 4.026" | 2667 PSF | 54 INCH | 50 INCH | 4 | 7 EA. | 8 Cu Ft | 0.5 CF | 18" |
| 10000# | 5.563" | 5.047" | 4444 PSF | 54 INCH | 50 INCH | 4 | 7 EA. | 8 Cu Ft | 0.5 CF | 18" |
| 10000# | 5.563" | 5.047" | 3600 PSF | 60 INCH | 56 INCH | 4 | 8 EA. | 9 Cu Ft | 0.5 CF | 18" |
| 10000# | 5.563" | 5.047" | 2975 PSF | 66 INCH | 62 INCH | 4 | 8 EA. | 10 Cu Ft | 0.5 CF | 18" |
| 15000# | 6.625" | 6.065" | 3750 PSF | 72 INCH | 68 INCH | 4 | 9 EA. | 11 Cu Ft | 0.5 CF | 18" |
| 15000# | 6.625" | 6.065" | 3195 PSF | 78 INCH | 72 INCH | 4 | 9 EA. | 12 Cu Ft | 0.5 CF | 18" |
| 15000# | 6.625" | 6.065" | 3240 PSF | 60 INCH | 56 INCH | 8 | 8 EA. | 25 Cu Ft | 1.6 CF | 30" |
| 15000# | 6.625" | 6.065" | 3333 PSF | 54 INCH | 50 INCH | 8 | 7 EA. | 32 Cu Ft | 1.8 CF | 36" |

THIS IS A GUIDELINE FOR ESTIMATING, SITE SPECIFIC CONDITIONS SHOULD BE VERIFIED.
 This Drawing shall not be used nor reproduced except when authorized in writing by TrafficGuard,[®] Inc.

ROUND POST BOLLARD RPAS ANCHORAGE SYSTEM DETAILS

THIRD ANGLE PROJECTION 
 Do not scale from drawing

Toll Free **TrafficGuard,[®] Inc.**
 P.O. Box 201, Geneva, IL. 60134
 Bus: 1.877.727.7347 Fax: 1.800.814.7194

| | | | | | | | | | |
|------|------|----|-------------|--|---------|-----|-------------------|--------------------------|-----------------|
| 3 | - | - | - | | Action | by | | | |
| 2 | - | - | - | | Design | wkz | Dwg. Scale: nts | Assembly Shipping Weight | Drawing Number: |
| 1 | - | - | - | | Drawn | wkz | Copywrite: 2010 | Varies per Model | RPAS-2 |
| Rev. | Date | by | Description | | Checked | wkz | Dwg. Size: Letter | Drawing Date: 12.10.10 | Sheet: 2 of 2 |

VEHICLE DESIGN STATIC LOAD "P"
AT 27 INCHES ABOVE GRADE (NTS)

INSTALL TOP OF CONCRETE AND
ANCHOR POST AT GRADE

USE NOTED PIER "D"
DIAMETER SONOTUBE
IF NEEDED TO AVOID
CAVE IN AT TOP

ROUND POST ANCHOR
SLEEVE BY TRAFFICGUARD,[®]
Inc. AT CENTER OF PIER

4,000 PSI CONCRETE
PIER AT NOTED
DIAMETER & HEIGHT

#4 VERTICAL REBAR
AT NOTED QUANTITY
& LENGTH.

PVC DRAIN PIPE
AT LENGTH FROM
ROCK TO BOLLARD
AT DIAMETER TO
MATCH BOLLARD

#3 REBAR HOOP
TIES AT THE NOTED
PIER DIAMETER MINUS
4" WITH 12" TIE LAP
INSTALLED AT 2" CLEAR
FROM TOP & BOTTOM
OF PIER AS SHOWN

3 INCHES MIN.
THICK ROCK
FRENCH DRAIN
PIER BASE.

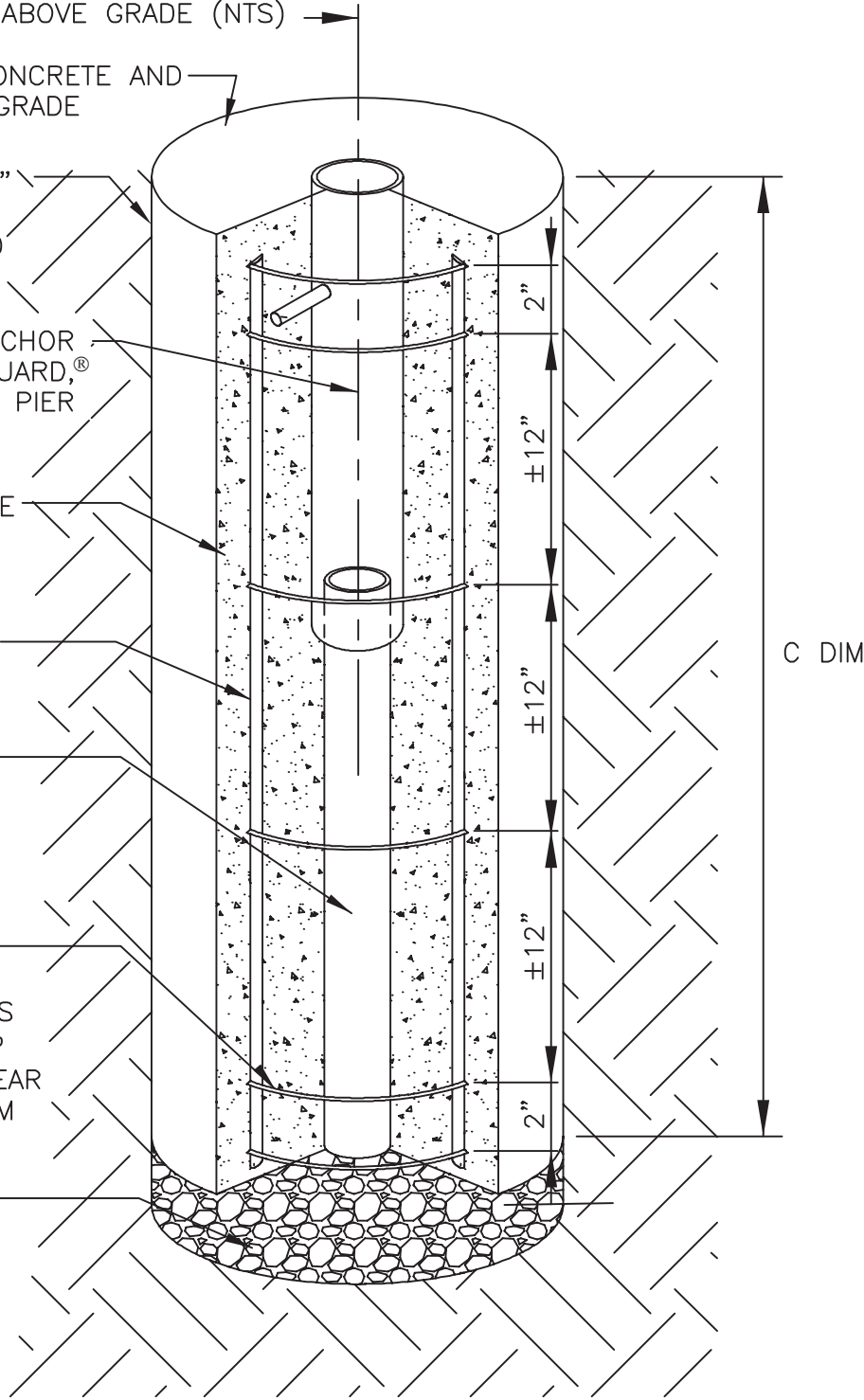

PIER ELEVATION SECTION

NOTE REFER TO RPAS-2 FOR THE ANCHORAGE SYSTEM DIMENSIONS, DESIGN LOADS, BOLLARD AND REBAR SIZE, QUANTITIES, AND EARTH PRESSURES THIS IS A GUIDELINE FOR ESTIMATING, SITE SPECIFIC CONDITIONS SHOULD BE VERIFIED.

This Drawing shall not be used nor reproduced except when authorized in writing by TrafficGuard,[®] Inc.

**ROUND POST BOLLARD RPAS
ANCHORAGE SYSTEM ASSEMBLY**

THIRD ANGLE PROJECTION 
Do not scale from drawing

Toll Free **TrafficGuard,[®] Inc.**
P.O. Box 201, Geneva, IL. 60134
Bus: 1.877.727.7347 Fax: 1.800.814.7194

| | | | | | | | | | |
|------|------|----|-------------|---------|-----|-------------|--------|--------------------------|-----------------|
| 3 | - | - | - | Action | by | Dwg. Scale: | nts | Assembly Shipping Weight | Drawing Number: |
| 2 | - | - | - | Design | wkz | Copywrite: | 2010 | Varies per Model | RPAS-1 |
| 1 | - | - | - | Drawn | wkz | Dwg. Size: | Letter | Drawing Date: | 12.10.10 |
| Rev. | Date | by | Description | Checked | wkz | | | Sheet: 1 of 2 | |